

***N.B. WARNING! FOR INSTALLATION ON MODEL 2022 -->**
 it is essential to use the bracket cod.3015305501 on the manifold to avoid damaging the original fairing.

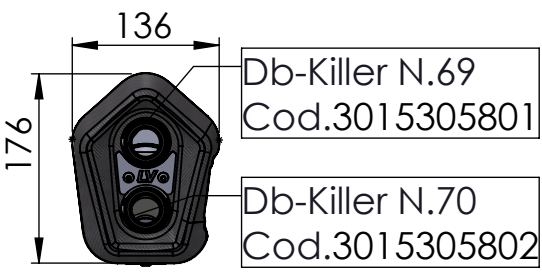

LV-12 silencer RHS
 Stainless steel
 Cod.3015305481

Aluminium spacer
 $\varnothing 27 \times 8,5$ Cod. 204321

Aluminium spacer
 $\varnothing 25-18$ L=40 $\varnothing 8,5$
 Cod. 202499

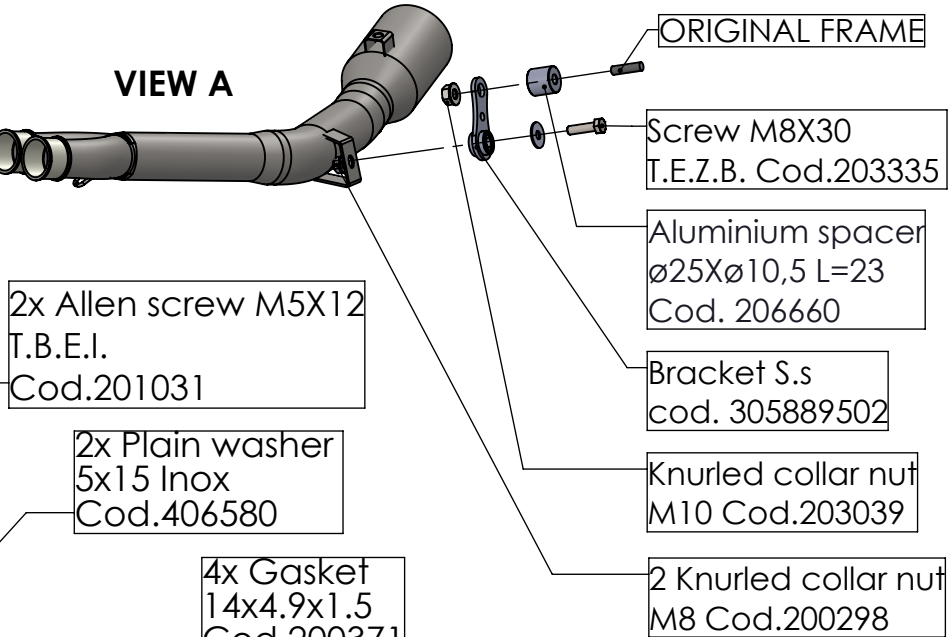

2x Allen screw M5X12
 T.B.E.I.
 Cod.201031

2x Plain washer
 5×15 Inox
 Cod.406580

4x Gasket
 $14 \times 4,9 \times 1,5$
 Cod.200371

Carbon cover
 cod. 0815300021

2x Mounting
 plate M5 Z.B.
 Cod.204555

2X Plain washer $\varnothing 8 \times \varnothing 24$
 Cod.200321

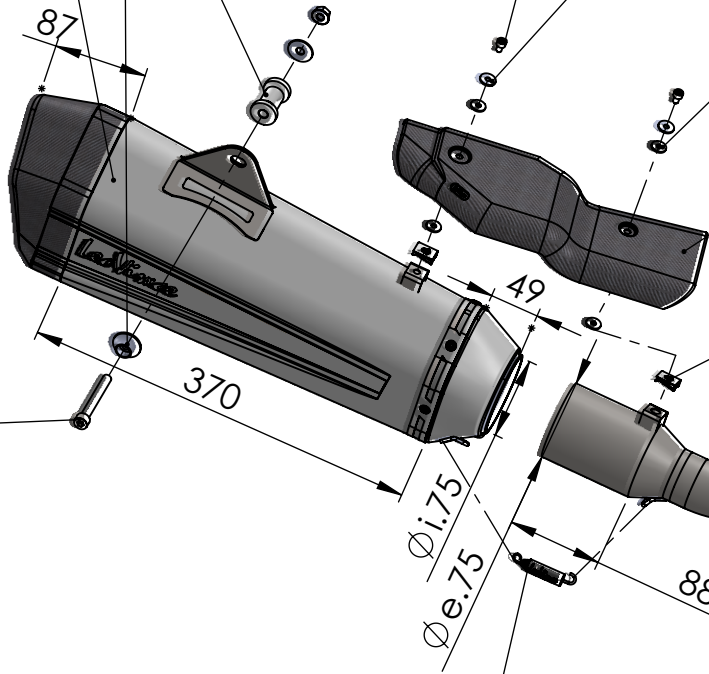

3x Short helical
 spring tensile
 cod. 303949001

Allen screw M8X65
 T.C.E.I.Z.B.
 Cod.201222

Pipe N°1332 s.s
 cod. 3015305203

OPTIONAL
 cod.5683

M12X1.25

s.s bracket with surflex
 cod.3015305501

Pipe N°1331 s.s
 cod. 3015305201

2x welded Bushing s.s.
 cod.206062

2x Flange 25B s.s. sp.6mm
 cod.200560

ART. 15305

YAMAHA T-MAX 560/TECH MAX

it is advisable to optimize the carburation by remapping the stock ECU or by adopting an additional ECU unit.

WARNING

SLIP-ON - LV-12 - STAINLESS STEEL - APPROVED