

I - ATTENZIONE: le valigie laterali BMW possono essere installate dopo il montaggio di questo silenziatore (con distanziale h=10mm e vite M8x40).

GB - WARNING: the BMW side cases can be installed after this silencer has been mounted (with spacer h=10mm and screw M8x40).

F - ATTENTION: les sacoches latérales BMW peuvent être installées après le montage de ce silencieux (avec entretoise h=10mm et vis M8x40).

D - ACHTUNG: BMW-Koffer können nach der Montage des Schalldämpfers angebracht werden (mit Abstandhalter h=10mm und Innensechskantschraube M8x40).

E - ATENCIÓN: las valijas laterales BMW pueden ser instaladas después del montaje de este silenciador (con el separador h=10mm y tornillo M8x40).

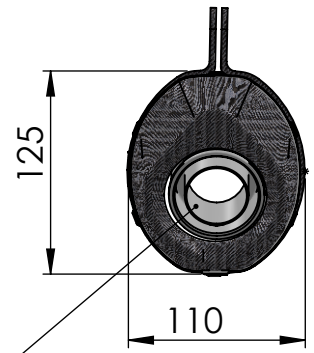

Db-Killer 32B
Cod.307762801

Aluminium spacer
ø27X8,5
Cod. 204321

Allen screw M8X40
T.C.E.I.Cod.200993

Aluminium spacer
ø20X8,5 h.10
Cod. 200414

Carbon clamp FB5AS
cod.308562501

E13 92R-01 10400

Knurled collar nut
M8 Cod.200298

Aluminium spacer
ø20X8,5 h.14
Cod. 201822

Knurled collar nut
M5 Cod.204407

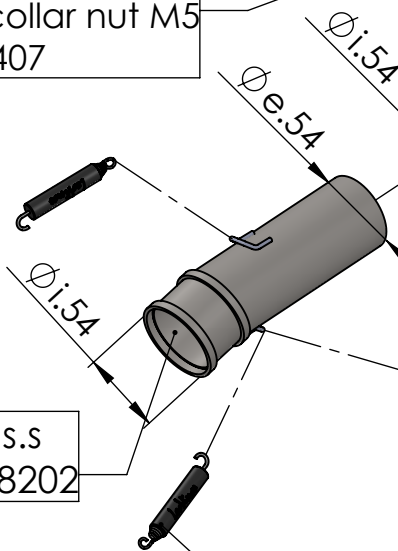

Pipe N°762 s.s
cod. 308238202

Short helical
spring tensile
cod. 303949001

2x helical
spring tensile
cod. 304982002

Allen screw M8X30
T.C.E.I.Z.B.
Cod.202491

Allen screw M5X14
T.B.E.I.
Cod.204805

LV ONE EVO silencer RHS
Carbon fiber
Cod.3014357482

ART. 14357E

BMW F 800 GT / F 800 R

(Fits with original panniers) (Also fits 35kW version)

SLIP-ON - LV ONE EVO - CARBON - APPROVED