

Bushing
Cod. 204640

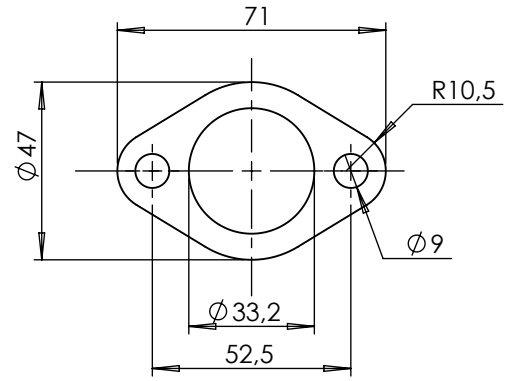

Flange 43E Sp. 5mm
Cod. 206308

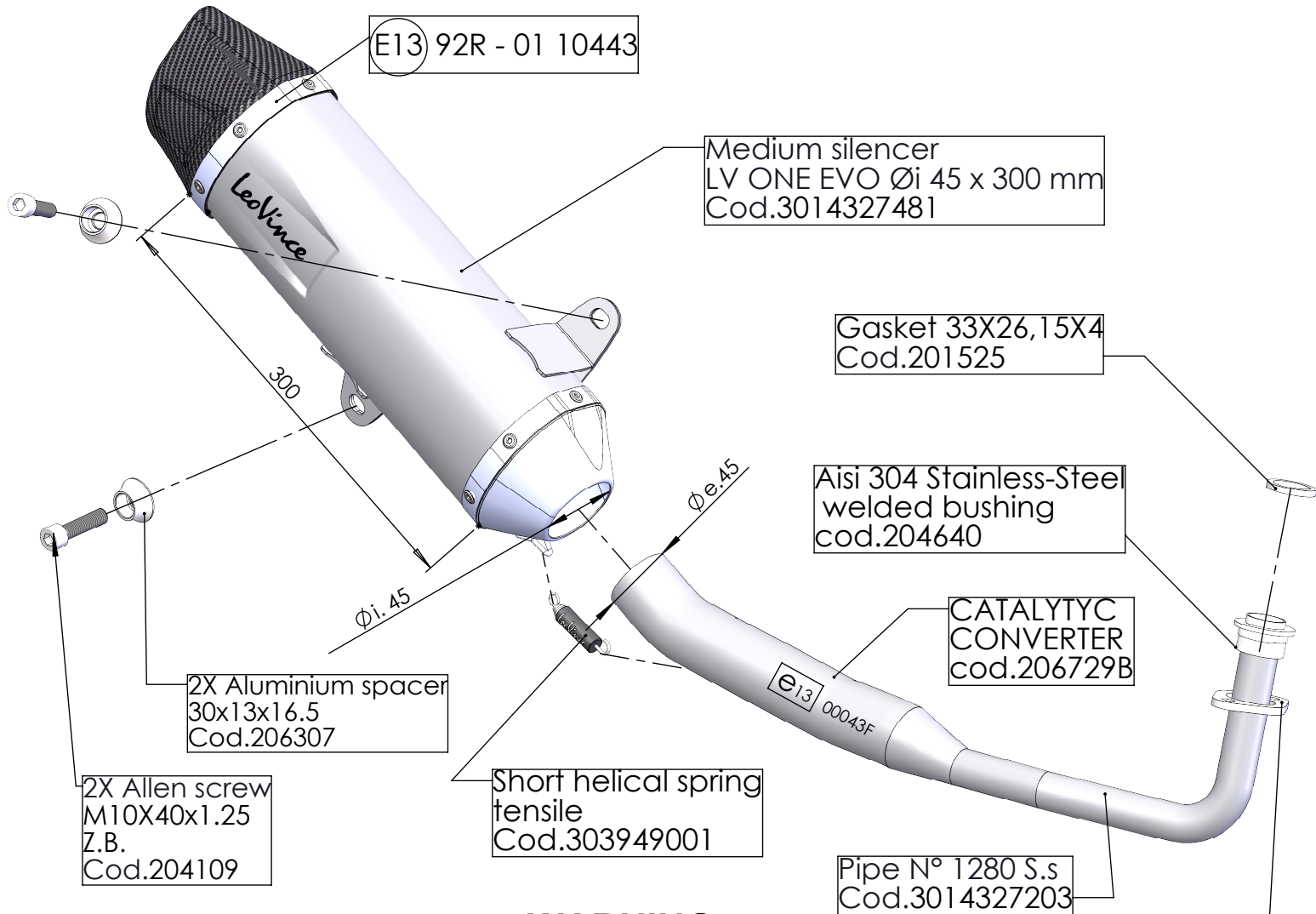

WARNING

it is advisable to optimize the carburation by remapping the stock ECU or by adopting an additional ECU unit.

ART.14327EK

HONDA PCX 125

FULL SYSTEM 1/1 - LV ONE EVO - STAINLESS STEEL - APPROVED