

dB-killer n.59B
Cod.3014228803

**BUSHER STAINLESS S.
COD.204870**

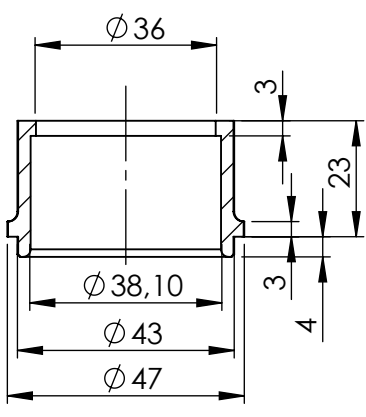

**FLANGE STAINLESS S.
COD.204448**

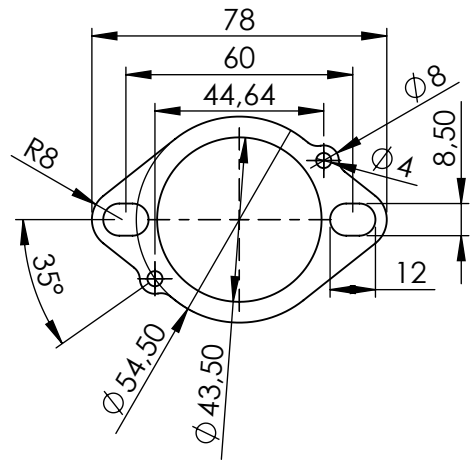

LV ONE EVO Silencer RHS
stainless steel black
Cod.3014228486

N°3Aisi 304
stainless steel flange
Cod.204448

N°7 Short helical spring
tensile
Cod.303949001

N°2Aluminium spacer
Ø 27x8,5x11
Cod. 204321

N°3Stainless Steel
Busher 38,1X36X27
Cod.204870

Allen screw M8X35
T.C.Z.B.
Cod.200319

Allen screw M8X16
T.C.Z.B.
Cod.200360

(E13) 92R-02 10423

3x Knurled collar nut M8
Cod.200298

OPTIONAL
Cod.5682

Pipe N°2
Cod.3014032202

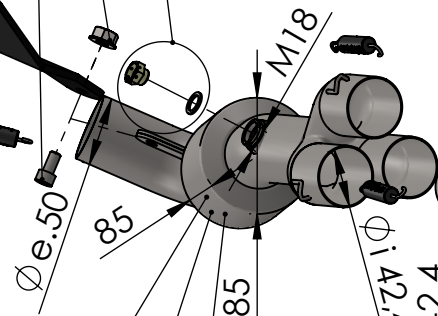
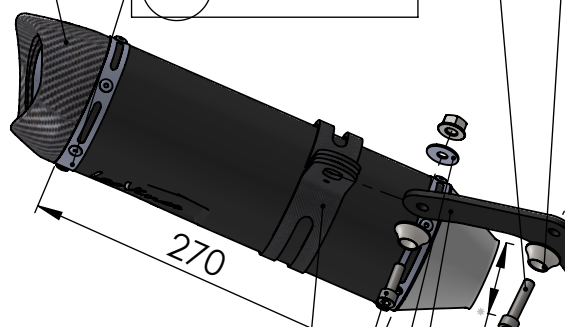

Carbon bracket FM4S
Cod.307572505

Allen screw M8X25
T.C.Z.B.
Cod.200314

Plain washer ø8xø24
Cod.200321

Stainless s. bracket
Prod. Cod.3014228501
Purch. Cod.206419

e13 0387 5

e13 00012 F

Pipe 3/1
Cod.3014228207

Pipe N°1
Cod.3014032201

Pipe N°3
Cod.3014032203

ART. 14228EKB

YAMAHA MT09/SP - MT09 TRACER/GT - XSR900

FULL SYSTEM 3/1 - LV ONE EVO -BLACK - APPROVED